

■ AC Power for  
Business-Critical Continuity™

# Liebert® NXL™ UPS 400 kVA - 800 kVA

*Enterprise-Scale UPS Protection For Medium and Large Data Centers*



  
**EMERSON**  
Network Power



**Emerson Network Power**, a division of Emerson, is a global company that combines technology with design to supply innovative solutions for the benefit of its customers.

Emerson Network Power is the leader in the “**business-critical continuity**” field, thanks to the company’s products and services.

Emerson Network Power’s broad technology base and global expertise support a full spectrum of enterprise-wide solutions for today’s vital business needs.



Regardless of your size, you can’t afford for your critical business systems to go down and you can’t waste time recovering your IT infrastructure after a disruption.

**Leave that to us**, the experts in *business-critical continuity*: from grid to chip, from the biggest to the smallest data centers, we are ready to serve your needs with the solutions we have developed.

More standardization, so you don’t need further budget allocations to install it. More simplification so you don’t need to be a specialist to get the best for your business. More support, so while you are enjoying doing business, we are protecting you.





## Liebert® NXL from 400 to 800 kVA

### Features and Performance

- Transformer-based architecture
- 12 pulse Silicon Controlled Rectifier (SCR) for 400-800 kVA units
- Input power factor >0.95 with automatic disconnection for input power factor control also at partial load
- Input THDi <5%
- Permanent 100% kVA – no derating with any load (leading or lagging)
- Temperature compensated battery charging/battery load test
- Continuous duty static bypass switch
- Automatic output power upgrade up to 10%
- Liebert® ActiveStar® Digital Signal Processor (DSP) control
- Interactive color touch screen user interface

The Liebert® NXL transformer-based UPS is designed to deliver reliable, efficient power protection for medium and large enterprise data centers, as well as government, healthcare, finance, telecom, manufacturing and transportation applications.

Featuring online double conversion technology, the Liebert® NXL provides excellent dynamic performance and flexibility, responding to all input conditions while maintaining high output power quality for critical loads. The Liebert® NXL furthermore achieves significant levels of energy efficiency through its intelligent parallel feature, delivering significant results at partial load, particularly in high availability parallel configurations. The transformer-based technology of the Liebert®

NXL further delivers superior reliability in critical installation environments as a result of its extremely robust architecture. At the same time this technology ensures galvanic isolation while operating online.

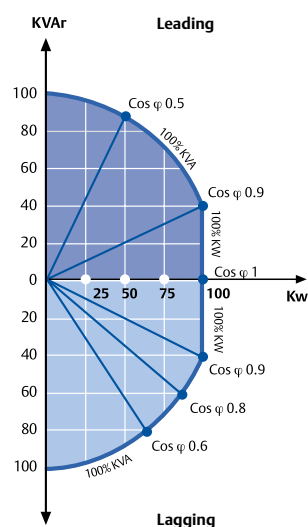



# Continuous Availability

The Liebert® NXL ensures maximized availability of connected loads. Its robust architecture allows operation at 100% load also when presented with a combination of critical conditions that would require other manufacturers systems to de-rate output or compromise system availability.

Furthermore the Liebert® NXL's 100% continuous-duty static switch ensures maximum fault clearing capability in the case of extreme overload or downstream short-circuits.

It additionally manages battery ground fault conditions allowing

regular operation to be maintained without switching the unit to bypass.

Maximum availability is further enhanced through:

- High inverter overload capability allowing fully regulated power also in the event of overload and fault conditions
- Superior management of leading power factor loads
- Built-in galvanic isolation offering maximized noise reduction
- Excellent dynamic performance
- Unit level redundant components, power supplies & communication cards

100% Load
40°C Temperature
12 P SCR Rectifier
Any Leading or lagging loads
Battery Ground Fault Conditions



Liebert® NXL800 kVA

# Optimized Total Cost of Ownership

## Total Cost of Ownership Advantages

The architecture of the Liebert® NXL is designed to optimize overall total cost of ownership from installation through to operation. Its excellent double conversion efficiency of up to 94%, together with galvanic isolation, further contribute to maximizing the return on investment .

The Liebert® NXL's total cost of ownership advantages are further increased as a result of:

- Simplified front access for improved serviceability
- Improved cable access resulting in faster installation
- Up to 98% efficiency in Intelligent Eco-Mode™
- Optimized partial-load efficiencies

## Intelligent Paralleling

The Liebert® NXL can be connected with up to six units in parallel. Its intelligent paralleling capability optimizes efficiency at partial load, thus achieving superior running cost savings. This feature allows the system to automatically adapt the number of operating units to meet immediate load requirements, by switching the excess units to standby mode. This intelligent paralleling feature allows for an overall reduction in energy dissipation, hence minimizing related cooling system consumption.



Liebert NXL Intelligent Paralleling - Two Units @ 65% Load Each = 93.7% Efficiency

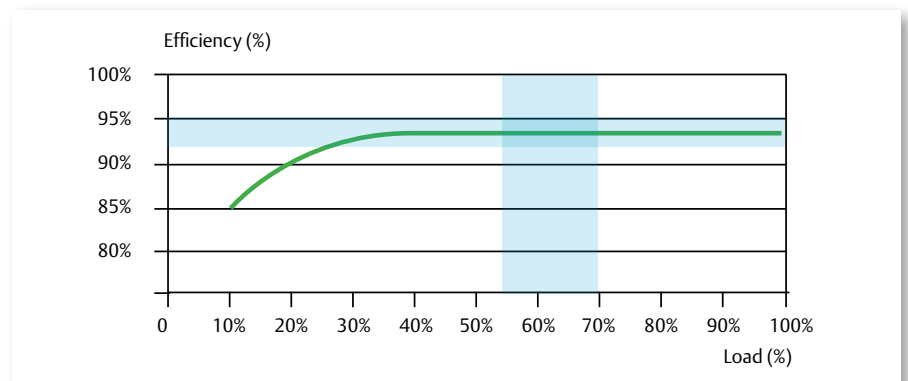

Liebert® NXL 400 kVA AC - AC efficiencies



## Flexible Configuration Capacity

The 400 kVA, 500 kVA, 600 kVA and 800 kVA high power ratings of the Liebert® NXL range maximize cost savings by reducing the number of overall units necessary to meet capacity requirements. This in addition greatly reduces the system footprint, thus providing space saving advantages and minimizing the demand on physical floor space, installation and maintenance related costs. The Liebert® NXL is available in multi-module configurations for Tier 2, 3 and 4 applications, ensuring the ideal level of power redundancy for all critical applications.

### Parallel Configurations

Liebert® NXL units can be paralleled with up to six units to obtain an increased level of capacity as well as higher redundancy, enhancing fault management capability by preventing single module or single battery failures. The parallel architecture of the Liebert® NXL allows single units to be serviced while the remaining units continue to power the load.

### Single-Unit Configuration

In a single unit configuration, the critical bus is powered by a single UPS providing an excellent level of

reliability and internal redundancy via its continuously rated internal static bypass.

### Distributed Parallel Configuration

Paralleling of single UPS units offers advanced scalability in terms of capacity and redundancy. Each unit has its own static bypass switch, providing parallel operation without the need for a system control cabinet, thus reducing initial installation costs. In the distributed parallel configuration, system level commands may be given directly to the single unit.

### Centralized Parallel Configuration

In a centralized parallel configuration the internal static bypass switch of each unit is disabled and an external Main Static Switch (MSS), rated for the desired maximum capacity, is installed. The MSS can be easily integrated into any switchgear, thus simplifying cabling. System level commands are given to the MSS which also provides centralized monitoring and simplified control of the complete system.

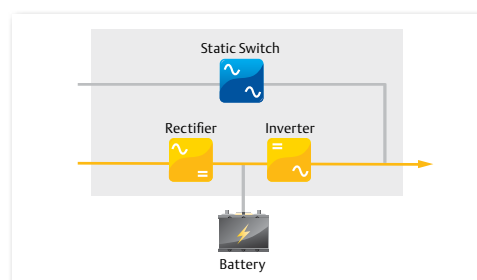

Single Unit Configuration

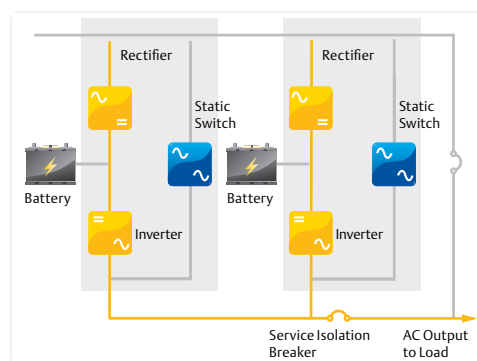

Distributed Parallel Configuration

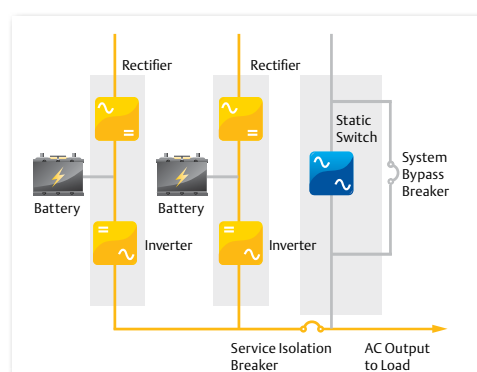

Centralized Parallel Configuration

# Advanced Touch Screen User Interface

The Liebert® NXL features a large, multi-language color touch screen interface allowing close control and monitoring of system status and performance.

The system's intuitive menu allows for:

- Quick checking of operational status
- Monitoring of power flow through UPS along with all meter readings
- Menu-driven operator procedures to ensure safe operation
- Checking of status reports and history files
- Adjustment of programmable parameters (access determined by security access function)

## Battery Cycle Monitor

Via the touch screen interface, users are able to monitor the expected runtime of batteries and take any necessary action accordingly.

The battery cycle monitor:

- Collects and retains information on the last 132 events involving UPS battery discharge
- Stores critical event details
- Provides onscreen access to information relating to battery health
- Status, warning and alarm notifications

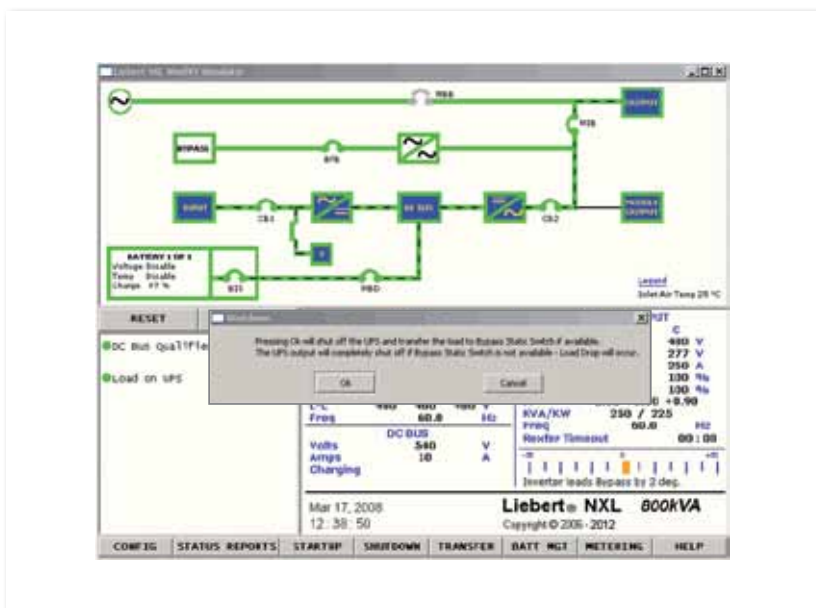

Liebert® NXL 800 kVA Touch Screen User Interface

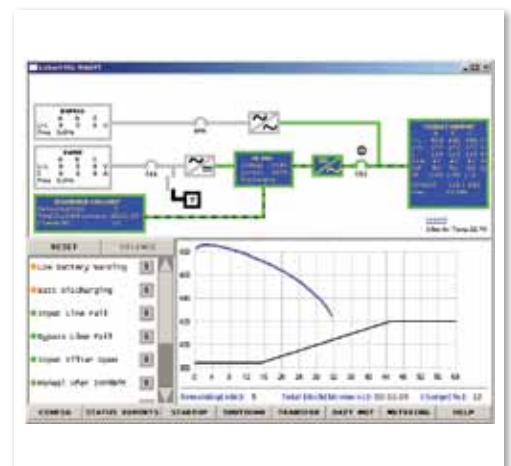

Battery Cycle Monitor





# Connectivity, Management and Monitoring

## Liebert® IntelliSlot™ Web Card

Liebert® IntelliSlot Web Card and the Liebert® IntelliSlot 485 interface card provide connection to Liebert® SiteScan Web, for access to real-time control plus the tools to analyze important equipment-related data. Both cards allow the operator to access current data and interact with graphic programming logic in real-time, for full control functionality.

control virtually any piece of critical support equipment. Its features include real-time monitoring and control, data analysis, trend reporting and event management. The Liebert® NXL comes with the ability to output data directly to the network for integration with other monitoring systems.

## Trellis™ Platform

Emerson Network Power's Trellis™ platform is a real-time infrastructure optimization platform that enables the unified management of data centre IT and facilities infrastructure.

The Trellis™ platform software can manage capacity, track inventory, plan changes, visualize configurations, analyze and calculate energy usage, and optimize cooling and power equipment as well as enable for virtualization.

The Trellis™ platform monitors the data center, providing a thorough understanding of system dependencies to help IT and facilities organizations keep the data center running at peak performance. This unified and complete solution, delivers the power to see the real situation in your data center, make the right decision and take action with confidence.



Liebert® IntelliSlot 485 Interface Card



Liebert® IntelliSlot Web Card



Liebert® SiteScan Centralized Site Monitoring

## Liebert® SiteScan® Web Centralized Monitoring Integration

Liebert® SiteScan Web is a centralized site monitoring system which ensures maximum visibility and availability of critical operations. Liebert® SiteScan Web allows users to monitor and

## Battery Monitoring Options

Alber battery monitoring allows continuous monitoring and diagnosis of battery parameters. The reporting function keeps users informed of battery health, and allows timely, proactive battery replacement avoiding premature replacement.





## *Servicing Critical Infrastructure*

Proactive equipment maintenance reduces downtime and extends equipment life which in turn maximizes return on investment and increases system availability. Emerson Network Power supports entire critical infrastructures with an extensive service offering, guaranteeing network availability and total peace of mind 24/7.

LIFE™.net, Emerson Network Power's remote monitoring service, ensures that your critical power protection system is maintained in an optimum state of readiness at all times.

LIFE™.net remote monitoring and diagnostic service provides early warning of UPS conditions and out of tolerances. This allows effective proactive maintenance and fast incident response, giving customers complete security and peace of mind.

### **Maximize Availability**

#### **Pre-Emptive Maintenance**

LIFE™.net provides early warning of more than 150 separate parameters allowing real-time diagnosis and swift identification and resolution of operating anomalies.



### **Minimize Downtime**

#### **Immediate Identification of Problems**

Should an emergency condition arise, an engineer in the 24/7 manned service center carries out an immediate fault analysis and instigates appropriate corrective action.



### **Reduce Operating Costs**

#### **Superior Asset Management**

Through comprehensive data collection and analysis, LIFE™.net's detailed reporting system provides valuable information on power and equipment trends, over any selected period of time.





# Liebert® NXL™ UPS

## Specifications

Technical Characteristics				
Rating	400	500	600	800
Apparent nominal output power at 25° C (kVA)	440	550	660	880
Apparent nominal output power at 40° C (kVA)	400	500	600	800
Maximum output active power at 40° C (kW)	360	450	540	720
Input				
Nominal mains input voltage/voltage tolerance (V)	400 (285 to 460), three phase			
Nominal bypass input voltage/voltage tolerance (V)	400 ± 10% (380 V, 415 V selectable) three-phase + neutral			
Nominal input frequency/frequency tolerance (Hz)	50 ± 10% (60 Hz selectable)			
Input Power Factor	> 0,95			
Input current distortion at maximum input power THD (%)	<5			
Output				
Output voltage stability by load variation 0 - 100% (%)	± 1			
- static	Complies with IEC/EN 62040-3, Class 1			
- dynamic				
Output frequency (nominal) (Hz)	50 (60 Hz selectable)			
Output frequency variation (%)	± 0.75 (1.5, 2.5, 6.0 selectable)			
- with mains synchronization	± 0.05			
- with internal reference				
Inverter overload capacity	125% for 10 min., 150% for 1 min.			
Compatibility with loads	Any power factor (leading or lagging) up to 0.9; crest factor up to 3:1			
Automatic adjustment of nominal output power with temperature	110% at 25°C, 100% at 40°C			
General				
Operating temperature (°C)	0 - 40			
Recommended battery temperature (°C)	+15/+25			
Relative humidity (without condensation at 20°C)	<95%			
Protection level	IP 20			
Color	ZP 7021			
Noise at 1 m (dBA)*	70	72	75	76
AC/AC efficiency (%)*	Up to 94			
Parallel configuration	Up to 6 units in modular or centralized parallel configuration			
Dimensions And Weight				
Height (mm)	1900			
Width (mm)	1620	2020	3270	3270
Depth (mm)	860			
UPS weight (kg)	2380	2780	4100	4100

\* Conditions apply



## Emerson Network Power Business-Critical Continuity™ Expert

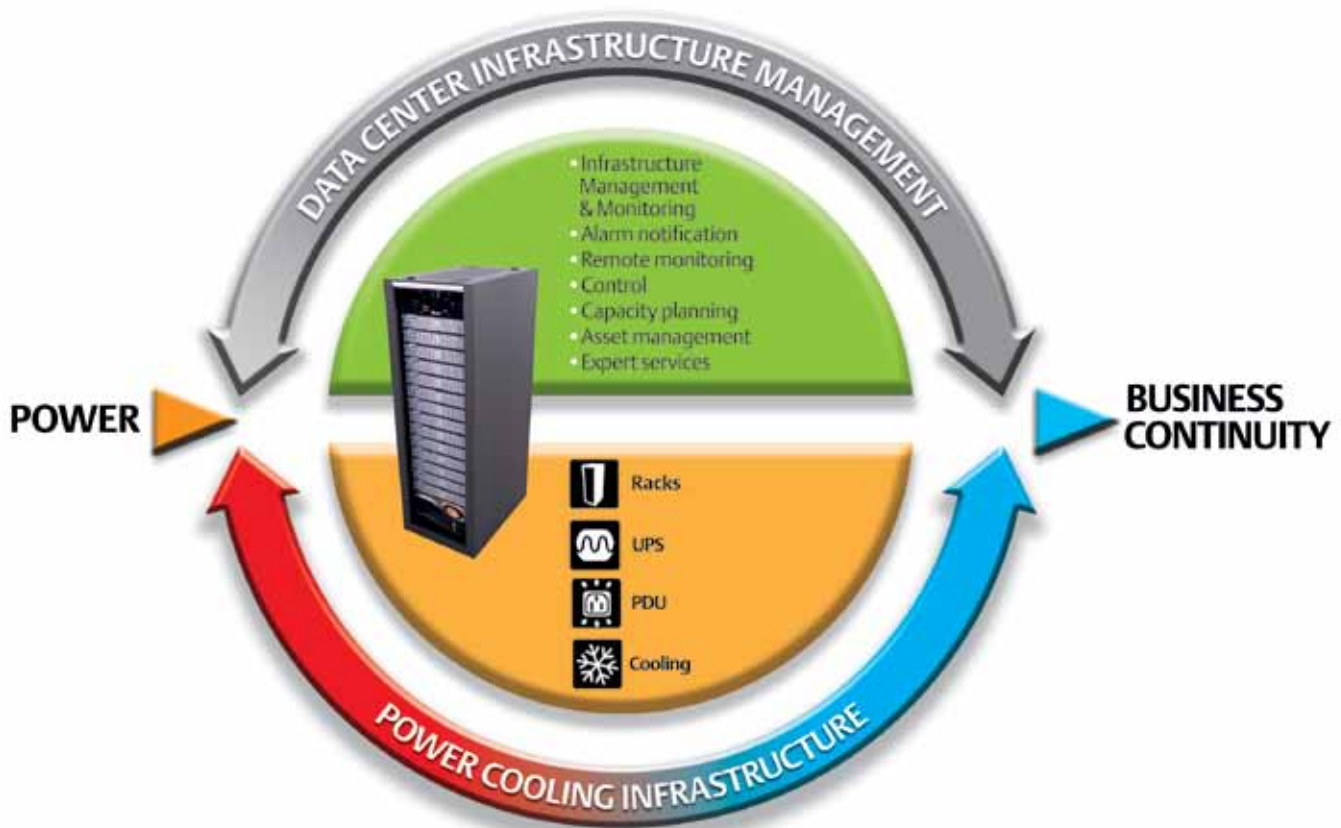

Today's successful businesses depend on adaptable technologies to help them respond quickly to market demands. Your data center must be built on a support infrastructure designed to match the power and cooling needs of rapidly changing IT initiatives such as virtualization and consolidation. Each IT change, move or addition will affect the entire support infrastructure so you need products and support that ensure your IT systems will operate reliably in these environments.

*Get more on line: [www.EmersonNetworkPower.eu](http://www.EmersonNetworkPower.eu)*



*More than 35,000 organizations in 70 countries depend on our Business - Critical Continuity™ Promise: your IT infrastructure stays up to support your Business!*

# Ensuring The High Availability Of Mission-Critical Data And Applications.

## About Emerson Network Power

Emerson Network Power, a business of Emerson (NYSE:EMR), protects and optimizes critical infrastructure for data centers, communications networks, healthcare and industrial facilities. The company provides new-to-the-world solutions, as well as established expertise and smart innovation in areas including AC and DC power and renewable energy, precision cooling systems, infrastructure management, embedded computing and power, integrated racks and enclosures, power switching and controls, and connectivity. Our solutions are supported globally by local Emerson Network Power service technicians.

Learn more about Emerson Network Power products and services at

[www.EmersonNetworkPower.com](http://www.EmersonNetworkPower.com)

While every precaution has been taken to ensure accuracy and completeness of this literature, Emerson Network Power and/or its affiliates makes no representations or warranty about the accuracy, reliability, completeness, or timeliness of the materials and disclaims any and all liability for damages resulting from use of this information or for any errors or omissions.

©2012 Emerson Network Power. All rights reserved.  
Specifications subject to change without notice.

MKA4L0UKNXL Rev.1-07/2012

## Emerson Network Power

The global leader in enabling *Business-Critical Continuity™*.

- AC Power
- Connectivity
- DC Power
- Embedded Computing
- Embedded Power
- Infrastructure Management & Monitoring
- Outside Plant
- Power Switching & Controls
- Precision Cooling
- Racks & Integrated Cabinets
- Services
- Surge Protection

## Locations

### Emerson Network Power

Via Leonardo Da Vinci 16/18  
Zona Industriale Tognana  
35028 Piove di Sacco (PD) Italy  
Tel: +39 049 9719 111  
Fax: +39 049 5841 257

Via Fornace, 30  
40023 Castel Guelfo (BO) Italy  
Tel: +39 0542 632 111  
Fax: +39 0542 632 120  
[enquiries.chloride@emerson.com](mailto:enquiries.chloride@emerson.com)

### United States

1050 Dearborn Drive  
P.O. Box 29186  
Columbus, OH 43229  
Tel: +1 614 8880246

### Asia

7/F, Dah Sing Financial Centre  
108 Gloucester Road, Wanchai  
Hong Kong  
Tel: +852 2572220  
Fax: +852 28029250